

FAMU-FSU College of Engineering

Operation Manual

Team #18

SAR Imager

Instructors: Dr. Nikhil Gupta and Dr. Chiang Shih

Sponsor: Michael Blue

Faculty Advisor: Dr. Dorr Campbell

NORTHROP GRUMMAN



*Submitted:
April 1st, 2016*

<i>Members:</i>	<i>ID:</i>
<i>Luke Baldwin</i>	<i>lrb11e</i>
<i>Josh Dennis</i>	<i>jad11d</i>
<i>Kaylen Nollie</i>	<i>kn11e</i>
<i>Desmond Pressey</i>	<i>drp14</i>



Table of Contents

Table of Figures	iii
Table of Tables	iv
ABSTRACT	v
1. Functional Analysis	1
1.1 Introduction	1
1.2 Project Objective	1
2. Project/Product Specification	3
3. Product Assembly	5
3.1 Structure Assembly	5
3.1.1 Assembly of Base Back Connection Bar	5
3.1.2 Assembly of Baes Front Connection Bar.....	5
3.1.3 Assembly of Base Wheel Supports (x2)	6
3.1.4 Joining the Back Connector and Wheel Supports.....	6
3.1.5 Completing the Base	6
3.1.6 Mounting the Vertical Beam.....	6
3.1.7 Horizontal Arm Legs (x2).....	7
3.1.8 Horizontal Arms (x2).....	7
3.1.9 Component Box Legs (x2).....	7
3.1.10 Arm Handles (x2)	8
3.1.11 Castors and Plates (x4).....	8
3.2 Horn Assembly.....	8
4. Operational Instructions	10
4.1 Attaching Horns to Structure.....	10
4.2 Adjusting Horns	10
4.3 Alignment of Antennas	10
5. Troubleshooting and Spare Parts	11
6. Regular Maintenance	12
Appendix	13

Table of Figures

Figure 1: Antenna Array Creating Image (1).....	2
Figure 2: Structure - Front View.....	4
Figure 3: Fully assembled structure.....	8
Figure 4: Horn holders.....	9
Figure 5: Structure - Side View.....	13

Table of Tables

Table 1: Parts and Description..... 3

ABSTRACT

Synthetic Aperture Radar is an advance technique of measuring a high resolution radar signature with a smaller antenna. The purpose of this project is to use SAR technology to create a low-resolution image for homeland security applications. Our product will be able to scan individuals for metal objects in order to designate people who need additional security screening. From contact with our sponsor, Northrop Grumman, our team has developed a concise problem statement: “Design an improved housing structure for the SAR Radar array.” This project is a continuation from last year’s senior design group. New objectives for this year include lowering the weight, making the structure more stable, fixing the antenna horn mounting and alignment, and reducing cost. The purpose of this document is to provide the reader with the knowledge to build and operate the design.

1. Functional Analysis

1.1 Introduction

In partnership with the FAMU/FSU College of Engineering and Northrop Grumman, the objective of the Synthetic Aperture Radar (SAR) Imager Project is to develop a low-cost weapon detection system that provides suitable imagery resolution for physical security and military force protection applications.

Current detection technologies commonly employed in the security industry such as metal detectors, Advanced Imaging Technology (AIT) scanners, and x-ray scanners can be expensive, obtrusive, and require the subject to be inside the apparatus. An imager based on SAR technology, composed primarily of commercial-off-the-shelf (COTS) components, can be implemented at a lower cost than many industry-standard scanners; it may be placed behind a barrier, out of view from subjects; and most importantly, it can identify concealed metal objects from a distance.

In environments with multi-layered physical security protocols, the SAR imager's superior range can alert security professionals to potential threats before they reach an access control point, or before they progress further into a secure area, depending in which security layer the SAR is deployed. Some environments may be vulnerable to physical attack, but conventional AIT body scanners are too obtrusive or inefficient. An amusement park, for instance, might have high-level security needs, but their customers would not tolerate stepping into a full-body scanner.

Furthermore, random screening protocols have been widely criticized for being culturally or racially biased in practice. With SAR capability, guests can be discreetly imaged while queuing, and persons of interest can be identified for additional screening based on the presence of metal signatures rather than the caprice of a human screener.

This project is a continuation from last year. The first team to work on the project made major progress in pathfinding for this very unique, challenging project. While the work done by last year's team was an impressive feat for a first generation product, there are many things that can be improved upon this year. Two engineering teams are assigned to this project: one Electrical, and one Mechanical team. While the two groups work in tandem, this report will primarily consider the scope of the mechanical engineering team.

1.2 Project Objective

Our objective is to make a SARS imager with a purpose of creating a strong security system to protect against threats in public places such as movie theaters and stadiums. People are able to conceal weapons such as handguns or even bombs in public areas without anyone having any knowledge that someone has a weapon and could be a potential perpetrator of mass murder or anything with malicious intent. The difference between a tradition SARS imager is that this device

will be on the ground with a target that is horizontal and also that the device will have multiple stationary antennas that is sending data to be stored electronically by taking images of a target that is moving, specifically a human being. Instead of using it in the air, this will be used on the ground and taking images horizontally. The imager should be fully functional, uses materials that are commercially used and low in cost, and also creates a low but useful resolution of an image that can detect concealed weapons.

Because this is a stationary SAR, multiple antennas must be used to create the synthetic length of the radar. There are 16 antennas that transmit radar, and 4 that receive – the 4 outermost antennas. The received signal will be passed to the electrical components for modification, and that data will be sent to a laptop for post-processing. The output will be low-resolution display of the 40x40 inch scene. This system is shown in Figure 1.

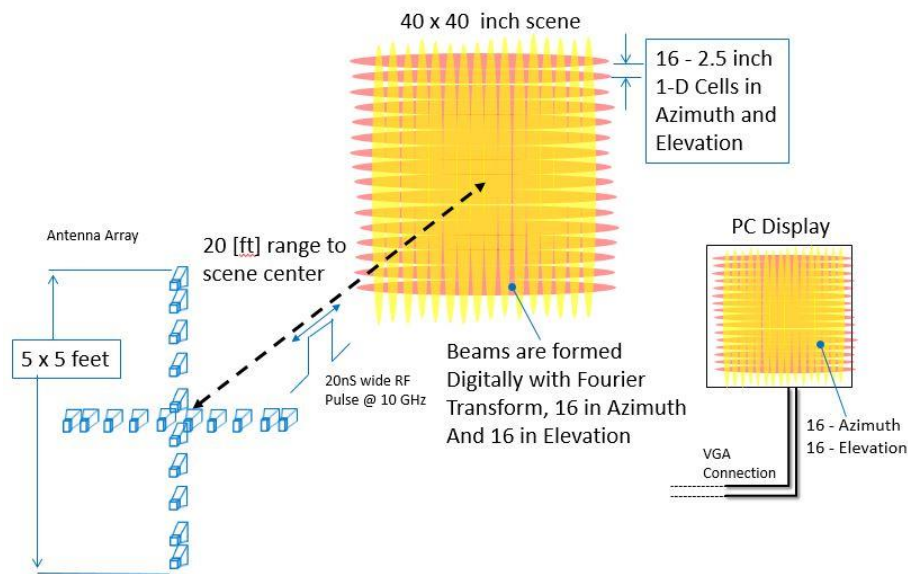

Figure 1: Antenna Array Creating Image (1)

2. Project/Product Specification

Table 1 is the parts list which includes the dimensions for each part used for design for the Synthetic Aperture Radar System.

Table 1: Parts and Description

1	.249 3003 H14 Aluminum Sheet, 12" x 12"	HORN HOLDER	Amazon	1
2	.125 6061 T6 Aluminum Sheet 12" x 12"	TESTING	Amazon	1
3	6" DIGITAL CALIPER	TOOLS	Home Depot	1
4	5" DIGITAL PROTRACTOR	TOOLS	Home Depot	1
5	MACH SCR FL HD PH ZINC #6-32X1/2"	HORN HOLDER	Home Depot	2
6	MACH SCR RND HD CMB ZINC #8-32X3/4"	HORN HOLDER	Home Depot	1
7	WASHER LOCK EXT TOOTH ZINC #6	HORN HOLDER	Home Depot	1
8	WASHER LOCK MED SPLIT SS #6 18-8	HORN HOLDER	Home Depot	1
9	100 FT. LINE REEL - TWISTED GOLD	TESTING	Home Depot	1
10	8020 Products	STRUCTURE	Adams Air	
11	Aluminum 6061, 0.125" x 2" x 36"	TOOLS	Online Metals	1
12	Aluminum 6061, 0.125" x 12" x 24"	TESTING	Online Metals	1
13	Aluminum 6061, 0.25" x 24" x 24"	HORN HOLDER	Online Metals	2
14	JLPS-20B <5mW Green Laser Pointer	CALIBRATION	Apinex	3
15	AmazonBasics 60-Inch Lightweight Tripod with Bag	TESTING	Amazon	1
16	AmazonBasics 60-Inch Lightweight Tripod with Bag	TESTING	Amazon	1
17	HDE Laser Eye Protection Safety Glasses	CALIBRATION	Amazon	2
18	43 PC Tool Set	TOOLS	Walmart	1
19	25 ft Measuring Tape	TOOLS	Walmart	1
20	22 PC Hex Key Set	TOOLS	Walmart	1
21	Bubble Level	TOOLS	Walmart	1
22	3D Printed Laser Clamp	CALIBRATION	Shapeways	1
23	8020 Products	STRUCTURE	Adams Air	
24	Thumb Screw, Knurled, 6-32x3/8 L, Pk5	HORN HOLDER	Grainger	4
25	Thumb Screw, Knurled, 6-32x1/2 L, Pk5	HORN HOLDER	Grainger	4
26	Machine Screw, Phillips, Oval Head, 6-32x3/8 L, Pk100	HORN HOLDER	Grainger	1
27	Machine Screw, Phillips, Oval Head, 6-32x1/2 L, Pk100	HORN HOLDER	Grainger	1

28	Mach Scr, Flat, SS, 4-40x1 L, Pk100	HORN HOLDER	Grainger	1
29	External Tooth Lock Washer, Pk100	HORN HOLDER	Grainger	1
30	Standard Split Lock Washer, Pk100	HORN HOLDER	Grainger	1
31	Mach Screw, Pan, 8-32x3/4 L, Pk100	HORN HOLDER	Grainger	1
32	C-RAM FAC-3 W/Velcro	TESTING	PPG Aerospace	16

Following are dimensions of the basic structure:

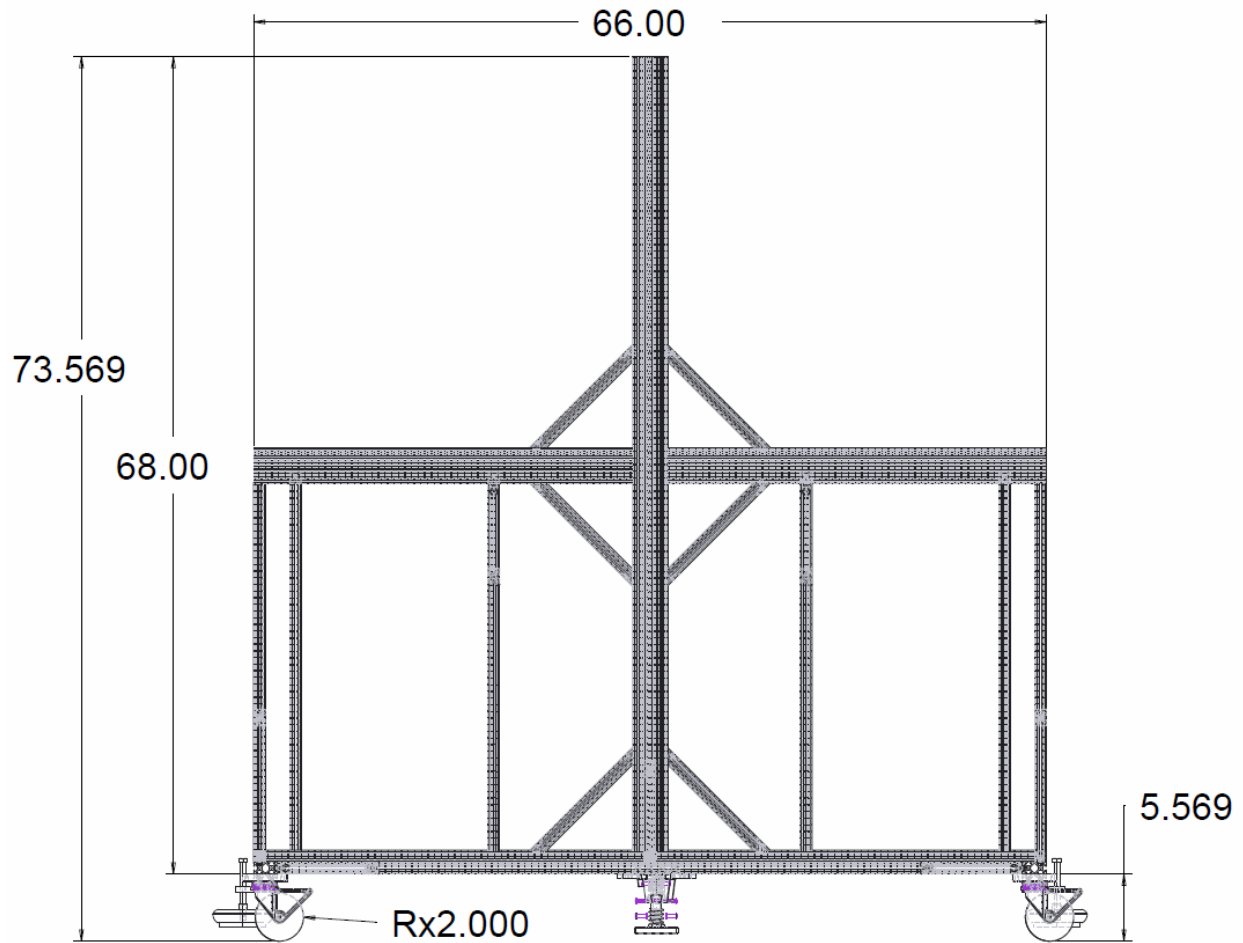

Figure 2: Structure - Front View

3. Product Assembly

3.1 Structure Assembly

As a general note, the design of the 8020 structure and the use of economy T-nuts forces all of the nuts to be inserted into the respective Aluminum before it is bolted together. After some pieces are joined, it will be impossible for economy nuts to be inserted through the end of the given 8020 piece. During assembly, it was found efficient to use two set of hands for alignment/assembly and to pre-connect all the connecting plates with the maximum screw and T-nut number. Two hex keys were required to assemble the structure sized 5/16" and 1/4". In terms of geometric channel convention, top refers to the channel that faces the sky, bottom for the channel facing the floor, front for channel facing the target circle--as if you were looking into the open antennas--and finally rear for the channels that points away from the back of the structure. Each paragraph explains the details for spacing connector plates and a subsequent assembly step for multiple beam sub-assemblies.

3.1.1 Assembly of Base Back Connection Bar

To assemble the structure first take one of the long 1010 Al pieces 62" long spanning from left to right. Then slide only one screw of the 4117 plate on the rear face with the examining screws faced upward about 10 inches from the center on either side. Take two of the 4136 connector plates and slide both of the screws on one side in on the top channel. Make sure that the vertical portion of unused connections points towards the middle of the beam right next to the 4117's. Next slide a 2570 piece of bracing 8020 through the front channel right near the end. Finally take a 4017 plate and slide one screw through the front face right after the 2570 with the other open screw pointing upwards.

3.1.2 Assembly of Baes Front Connection Bar

Take the second piece of 62" long 1010 and slide onto the rear channel the bottom row five screws of the 4201 plate. Leave the remaining 2x3 grid of screws facing upwards, this will be used to secure the main center beam. As on the Back Connector, take two 2570 brace's and slide one screw on to the front channel of each end. Take two more 2570 connectors and slide them through the top channel of the 1010 for additional center beam support. Finally take two holes of a 4117 plate and slide them into the bottom channel. The other open two screws will be used to connector to the wheel supports. Then slide one screw of a 4136 plate with the vertical open screws pointing away from the center of the beam.

3.1.3 Assembly of Base Wheel Supports (x2)

Two of these pieces will be made to a mirror image of the other. DO NOT make two of the same piece. Take a 30" piece of 1020 with the two x channels making a plane with a normal in the vertical direction. The length goes from front to back. On the very end of the top channel, slide two of the screws of a 4117 plate through the two parallel channels. Make sure that there are two screws on one side; do not split the 4117 in the middle of the 1020. To make the second Wheel Support, slide the other two end screws of the 4117 on the top of the channel with the open screws on the other side of the Aluminum bar.

3.1.4 Joining the Back Connector and Wheel Supports

The base of the SAR structure can now be completed. Take the pieces assembled in Steps 1 and 3. The Wheel Support 1020 with the open 4117 screws facing to the right will become the leftmost wheel base and vice versa. Take the hanging 2570 bracket on the 1010 piece and slide the open screw through the front of the right channel. Then slide the wheel base out to slide the open two screws of the 4117 piece through the top of the 1010 piece. Make sure that the rear of the 1020 and 1010 pieces are flush with each other. Then repeat this step on the other side. Tighten down these plates loosely so that the structure can be moved to slide the Base Front Connector Bar through the front.

3.1.5 Completing the Base

This piece is difficult to get into position due to the many connection points of Step 2 to the two Step 3 parts. First, slide the other open end of the 4136 plate hanging of the top of the 1010 into the inside top channel of the 1020 part 3 on each side. Simultaneously, align the exposed two screws of the 4117 on the bottom of the 1010 piece with the two parallel bottom channels of the 1020. This needs to be done on each side of the piece. Slid the Front Beam backwards and align the open side of the 2570 bracket mounted to the front face with the inside channel of the 1020 Wheel Base. Then slowly shimmy each side until the rear face of the Front Beam is 19" away from the rear face of the Back Beam. Immediately tighten down all the screws on the Back Beam and two Wheel Base Beams followed by those of the Front beam. The base is complete.

3.1.6 Mounting the Vertical Beam

Take the 66" long 1030 beam with the three parallel channels facing normal to the target in a vertical orientation. Align the two 2570 brackets attached to the top channel of the Front Beam to the left and right channels of the 1030 piece. Once threaded through, make sure the 2x3 set of open screws form the 4201 on the rear face of the Front Beam to the rear face of the Vertical Beam.

3.1.7 Horizontal Arm Legs (x2)

Now take on of the 31.5” pieces of 1010 and slide a 4117 connector with three screws into the left face. Slide the one remaining screw through the left face of the 1020 Wheel Support beam. Then slide the 1010 piece up to fit the right face through the open end of the 4136 joining the 1020 Wheel Support and 1010 Front Beam. Repeat this process for the other leg making sure the 4117 is on the outside and the 4136 is on the inside.

3.1.8 Horizontal Arms (x2)

Again we will make two mirror image parts. First slide a 2570 brace through the left and right faces of the Vertical Beam. Then in the rear face of the Vertical Beam, Slide the five screw row of a 4201 through the left most channel with the 2x3 grid of open screws. Now slide a 4136 on the inside face of the Part 7 addition with the unused nuts facing up and toward the inside of the structure. Now slide two screws of a 4117 on the top of the rear face of the Part 7. Now slide the 1030 Horizontal Arm of 31.5” from the outside toward the center with the bottom channel through the 4136 and two of the three rear face channels through the two open screws for the rear faced 4117. Now slide one end of a 4107 through the bottom channel with the open screw pointing backwards. Bring up the dangling 2570 Brace and slide the open end through the bottom face of the Horizontal Arm. Slide one more 4117 plate like the first before lining up the same way as the previous one. Next slide a 4136 on the bottom rear face channel with the open screws pointing towards the inside of the structure. Now you can slide the Horizontal Arm onto the open 2x3 grid of the 4201. Repeat this process on the other side making sure the vertical symmetry is preserved. This step will prove complicated in aligning the piece to make a perfect cross due to the tolerance in the Tnuts and plates. Make sure that the arms are level with each other and perfectly orthogonal to the center beam and you will complete this step.

3.1.9 Component Box Legs (x2)

Now take the 19” 1010 and the 31.5” piece of 1010 to make the back legs. Slide a 4136 on the front face of the 31.5” piece at the top with the other screws on the bottom face of the 19”. Then take a 4117 plate and slide three of the screws onto the outside of the 31.5” leg. Then slide the 19” horizontal portion of the leg onto the final screw of the 4117 also on its outside face. Repeat this process with the 4117 plate on the other side. The legs can now be attached to the structure. Slide the left leg through the open two nuts of the 4136 brace on the left face of the leg. Simultaneously slide the open three screws of the 4117 on the rear face of the leg from the Rear Beam. Now slide the front of the 19” Box Leg through the 4136 on the back of the 1030 Horizontal Arm and the three open screws of the bottom face 4117. After these are in place tighten everything down.

3.1.10 Arm Handles (x2)

Both of these pieces are identical and slide on the farthest from center open 4107 pieces of the Part 8 and the open 4107 pieces on the Rear Beam. It is important to note that 1050 series 8020 was ordered to save weight and offer a smoother grip for people to move the structure. However, the right length pieces were given to us in a 1030 cross section, impossible to make into a handle so extra 1010 was sacrificed to make this piece. Take a 19" piece of 1010 and join a 4136 plate to the bottom face with the unused nuts point toward the rear. Then slide the 31.5" 1010 piece through these holes so that the rear plane of the 31.5" piece is flush with the rear plane of the 19" piece. Attach these arms to the open two 4107 plate and tighten down everything. At this point the structure is completed

3.1.11 Castors and Plates (x4)

First make sure that the 2406 Caster Plates have 4 screws in a 2x2 grid to match up with the 1020 Wheel Base Beam. Rotate the structure face up to add the top casters. Slide the 2x2 grid onto the bottom face of the 1020 arm aligning the edge of the 1020 with the edge of the 2406 and tighten. Then take the 2714 Leveling Caster and screw it onto the four screws of the plate. Repeat this step on the other 1020 Wheel Base. Then rotate the structure with the face down and repeat the same process on the back two casters making sure that the edge of the 2406 is lined up with the edge of the 1020 Wheel Base. Once this is completed, the structure is fully assembled.



Figure 3: Fully assembled structure

3.2 Horn Assembly

The Synthetic Aperture Radar System has two main components that are the focus for the mechanical aspects of the design: the structure and the horn holders. The structure is made of 8020 material and the horn holder's attachment piece is also made of this material. The attachment

piece is shown in Figure 4 and slides in the slots of the structure's design, which is shown in Figure 3. The horn holders are also able to move in both azimuth and elevation while still being able to be locked, using screws, without affecting any degree of freedom. The components of the horn holders which causes movement in the azimuth and elevation are also shown in Figure 4.

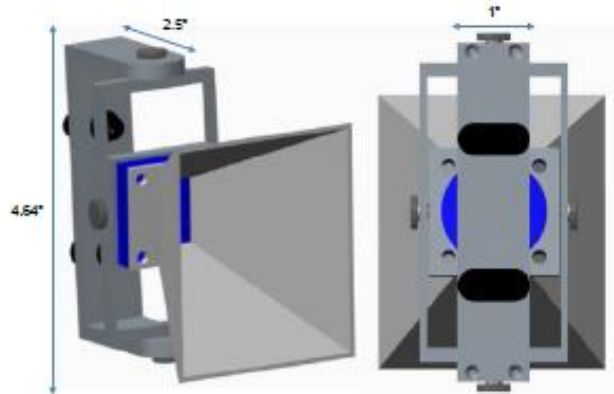

Figure 4: Horn holders

4. Operational Instructions

Operations for the structural portion of the project include attachments of the horns to the structure, alignment of horns, and adjusting of horns in desired degrees of freedom.

4.1 Attaching Horns to Structure

Figure 3, is an illustration of the structure's design. The design is already assembled, the only assembly needed is that of the attachments of the horns onto the structure. In order to attach the horns to the structure there is a piece, as referred to in the *Product Assembly* portion of the operation manual, that is compatible with the 8020 structure and that piece slides in the T slots of the extruded aluminum of the structure pieces. All 20 horns have this attachment piece and is placed on the structure at the users desired location which is based off of the requirements needed on the electrical portion in order for the horns to be able to transmit, receive signals, analyze them, and produce the low resolution image as needed.

4.2 Adjusting Horns

The horns are able to move in 3 degrees of freedom. One degree is where the horn is able to slide on the structure's surface. Another degree of freedom is in the azimuth direction and the other is in elevation. All degrees of freedom are free from one another meaning they are able to be locked in place while the other degree can be adjusted as need be. To adjust each degree of freedom you must either loosen or tighten the screws on the horns which is shown in Figure 4.

4.3 Alignment of Antennas

The laser calibration device is shown in Figure 5. A 3D Printed parts was created to fasten to the antenna horns during calibration by attaching the outer brackets to the horns. Once the brackets are attached then the laser can be put inside the device and attached to the horn. The laser can then be adjusted, and is calibrated once the laser is within the 1ft circle.

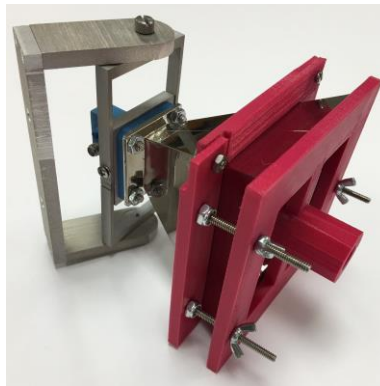

Figure 5: Laser Horn Alignment

5. Troubleshooting and Spare Parts

For the mechanical aspects of the project, there may be a few potential problems. In order to prevent these problems, there are methods put in place.

The design of the Synthetic Aperture Radar System is made up of 20 horn holders and a single structure that each horn is attached to. The horns are able to be adjusted and taken off of the structure. In the adjusting and removal of the horns from the structure, the horns could potentially be damaged or misplaced. To prevent no function ability in the design, there must be a spare horn that is fully operational carried around with the Synthetic Aperture Radar System. There will also be some sort of case that is used for all parts not attached to the structure and for transporting and protecting important components.

Another potential problem is with the screws. Since the horn holders on the structure will be adjusted, which means that the screws that are used for attachment and adjusting will be loosened and tightened. The chances of the screws being lost or dropped is very high so extra screws are to be carried along with the full structure.

6. Regular Maintenance

The Synthetic Aperture Radar System has a design which needs little maintenance after being built. The structure is made mostly of extruded aluminum and the material properties of aluminum are ideal for the project scope. The system will not be dealing with any extreme climate change or any great deal of stress and aluminum is high in strength, highly resistant to corrosion, and has great workability for the mechanical aspects of the design.

The only maintenance needed for the mechanical aspects of design should be annual checkups making sure that every component is still in place. The person checking the material should check for any possible structural or horn damages and loose screws that hold key components in place.

Appendix

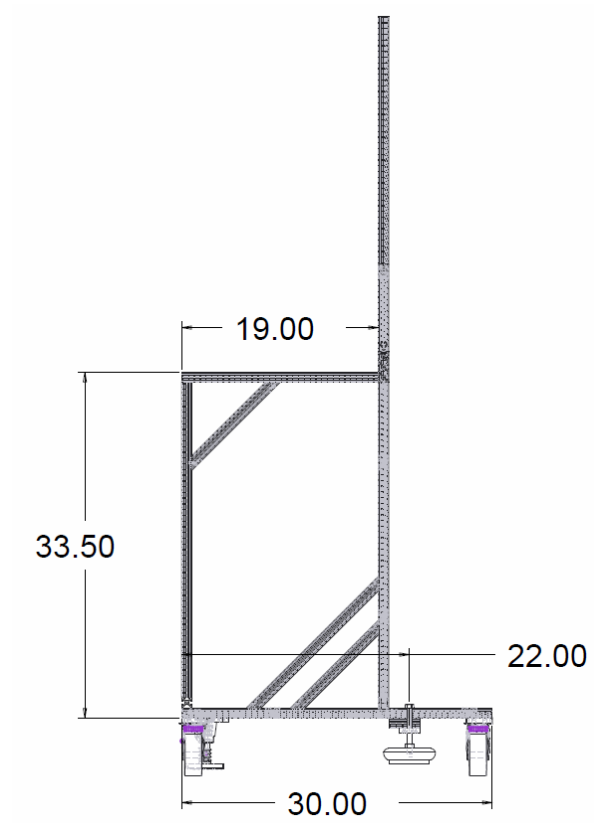

Figure 6: Structure - Side View